

Revolabs Fusion™ Wireless Microphone System

User's Guide



Rev 1.1

Table of Contents

Using the Fusion IR Remote Control	4
Using the Fusion Charger Base	6
Using the Revolabs Solo™ Microphones	8
Wearable Microphone	8
Tabletop Microphone	10
XLR Adapter for Dynamic Microphone	12
Indicator Lights	14

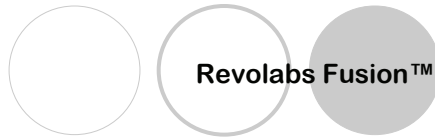

Great audio, wireless mobility, and simple to install!

Simply plug the cable into the AV system or phone system and it works. No software configuration is necessary. Even the Fusion box is designed to be easy to use– vertically or horizontally. No equipment rack needed. Just set the Fusion system on the credenza.

Video Conferencing

Revolabs Fusion Wireless Microphone Solution is compatible with all of the major video-conferencing solutions, including Lifesize, Polycom, Sony, and Tandberg. It includes a remote control. Decide on where you want to put the Fusion system, whether you want to place it vertically or horizontally, plug in the cables and you are ready to have great wireless audio in any conference room.

Audio Conferencing

Plug the Fusion Wireless Microphone Solution into an analog telephone jack and you are on your way to great wireless teleconference calls. There is a remote control dialer to dial the conference phone number. You may connect to powered speakers, connect to existing speaker system or connect to a new room speaker system to hear the call. Decide on where you want to put the Fusion system, whether you want it vertical or horizontal, plug in the cables and you are ready to have great wireless audio in any conference room.

Flexible

The Fusion System supports any combination of Solo Wireless Microphones- Wearable, Tabletop, or XLR adapter for s handheld microphone. Choose the right microphone for your meeting dynamics.

Rechargeable

Revolabs Wireless Microphones have a rechargeable battery that provides eight hours of talk time after each full charge. Revolabs Wireless Microphones recharge to 85% capacity in approximately 45 minutes.

Secure

All of Revolabs Wireless Microphones use 128-bit authentication, so that no one can listen in.

Using the Fusion™ IR Remote Control



Phone Dial Pad

Vol +: increases volume
Call: dial-tone
End: hang-up
Vol -: decreases volume

Flash: phone function
Redial: phone function

Dial a Call

To make a call, push “Call” to get dial tone, then dial the phone number on the Phone Dial Pad.

Answer a call

To answer a call when the system is ringing, push “Call”,

Mute and Unmute a Call Using Remote Control Mute Button

To mute all of the microphones, press the red MUTE button; all microphones will flash red and no individual microphone can be unmuted until the remote MUTE button is pressed again. To unmute, press it again. All microphones will return to their prior state.



NOTE: In the default setting, each Solo microphone will mute only itself when its MUTE button on the microphone is pressed. To mute all of the microphones, press the red MUTE button on the Remote Control; all microphones will flash red and no individual microphone can be unmuted until the remote MUTE button is pressed again. All microphones will return to their prior state.

However, if the tabletop microphone master mute has been enabled (Refer to Set-Up Guide), the mute will work as follows: in addition to the Remote Control MUTE button muting all of the microphones, the Solo Tabletop microphone MUTE button will also act as a master mute and mute all active microphones. Pressing any Tabletop microphone MUTE button or the Remote Control MUTE button will unmute all tabletop microphones. All wearable and handheld adapter microphones in use will return to their prior state.

End a Call

To end a call, the user must push “End”, even if the other callers have hung up.

Redial a Call

To redial a the last phone number, push “Redial”.

Adjust Volume

To increase and decrease the volume , use the Vol + and Vol- buttons.

Flash Button

“Flash” works according to your phone system.

Using the Fusion™ Charger Base

When microphones are not in use, they should be properly inserted into the Charger Base. It is important to ensure that the system microphones are inserted fully in the base so that charging will occur.

1. **LED indicator** — power / mute status indicator
2. **Charger Bay** — charges up to 8 Microphones.
3. **Power Cord Receptacle**— power supply input (on rear)

The Charger Base requires 5VDC power, provided by the AC Adapter. Plug the supplied AC wall adapter into an appropriate power outlet | 110-240 AC, 50-60Hz. The power LED on the Charger Base will illuminate.

Charging the Microphone Batteries

First-time use — before using the wireless microphone the first time, charge the batteries in the microphones for eight hours (or overnight) in the Charger Base.

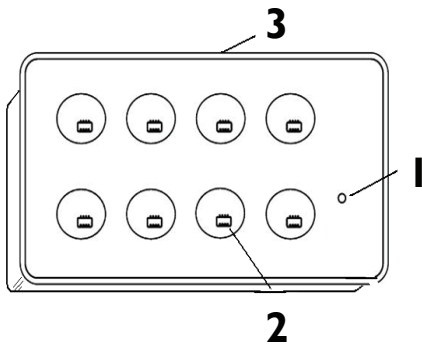



Recharging — when the YELLOW LED starts to flash intermittently on the microphone the battery has 30 minutes of charge remaining. To charge the batteries place microphones into the Revolabs Solo™ Executive Charger Base and the mic LED's will display a 5 blink "self test". During charging, the LED indicator will be RED when mics are discharged and turn GREEN when charged. The microphones are muted while in the Charger Base. In normal use, batteries should fully charge in about 2 hours, and can be "quick-charged" to 85% capacity in 45 minutes. Over time (years), batteries gradually wear down and require longer charging times. This is normal. Always return microphones to the Charger Base when not in use.

The batteries of microphones left in the Charger Base remain solid GREEN.

Important: *The Lithium Polymer rechargeable batteries that power the microphones are not user serviceable. Please contact Revolabs (www.revolabs.com) or your AV service provider for replacement instructions and to assure the proper disposal method is used.*

Warning: *Never dispose of batteries in a fire because they may explode.*

NOTE: A fully charged battery provides approximately 8 hours of talk time



Using Revolabs Solo™ Microphones and Microphone Adapters

Use any Solo Microphone microphones with your Revolabs Solo™ Executive system:

- Revolabs Solo™ Wearable Wireless Microphone
- Solo Tabletop Wireless Boundary Microphone
- Solo Universal Wireless Adapter for Handheld Microphone

Using Revolabs Solo™ Wearable Wireless Microphone

The Revolabs Solo™ Wearable Microphones, shown in the following figure, are paired to the Base Station and can be worn on the user's shirt pocket, lapel or on a lanyard.

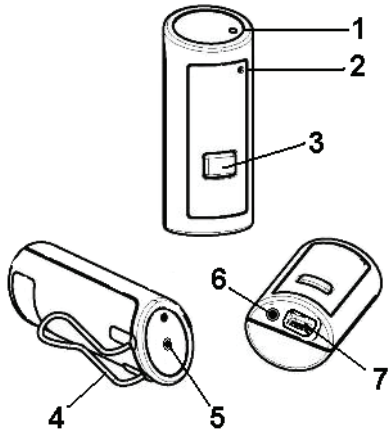

1. Microphone port — direct port toward mouth for best audio pickup.
2. Noise cancelling port — do not block opening.
3. Mute Button — press to mute, un-mute and pair microphone.
4. Pocket clip — also used to attach microphone to lanyard.
5. LED display — visual status for mute, un-mute, and pairing.
6. Earpiece jack — accepts the 2.5mm plug for the earpiece
7. Charging port — charges in Charger Base.



Revolabs Solo™ Wearable Microphones turn on and mute automatically when removed from Charger Base, to reduce noise while being attached. The microphone has a clip on the back which allows the microphone to be easily attached onto a shirt pocket, blouse, lapel or lanyard.

To use the Wearable Microphone:

- Remove the microphone from the Charger Base.
- Attach the microphone to clothing or to a lanyard close to the mouth, within 6 - 12 inches (15 – 30cm) is recommended. Make sure microphone is attached securely with the microphone port pointed up toward mouth.
- With the microphone in the wearing position, un-mute the microphone by pressing and releasing the Mute button (confirm by viewing flashing GREEN LED). If the volume is too low, move the microphone closer to the mouth.
- To turn microphones off, return the microphone unit to the Charger Base or press and hold the Mute button for ~10 seconds until the LED turns solid RED and release button.
- If the microphones are moved out of range of the Base Station (~100 feet or 30 meters) the connection will be dropped (LED flashes all colors) and the microphone will mute.
- After 15 seconds the microphone will beep 5 times, and will continue beeping every 30 seconds to remind the user to return the microphone to the conference room. If the microphone is moved back into range within 15 minutes the connection will automatically be re-established to its original state, and the beeping will cease. If not, the microphone will turn off.

Muting Microphones

In the default setting, each Solo microphone will mute only itself when its MUTE button on the microphone is pressed. To mute all of the microphones, press the red MUTE button on the Remote Control; all microphones will flash red and no individual microphone can be unmuted until the remote MUTE button is pressed again. All microphones will return to their prior state.

However, if the tabletop microphone master mute has been enabled (Refer to Set-Up Guide), the mute will work as follows: in addition to the Remote Control MUTE button muting all of the microphones, the Solo Tabletop microphone MUTE button will also act as a master mute and mute all active microphones. Pressing any Tabletop microphone MUTE button or the Remote Control MUTE button will unmute all tabletop microphones. All wearable and handheld adapter microphones in use will return to their prior state.

Using Solo Tabletop Wireless Boundary Microphones

The Solo Tabletop Wireless Boundary Microphones enable multiple conference attendees to use a single microphone.

The Tabletop Wireless Microphone, shown on the following page, is designed to provide optimum coverage when placed on a conference room table.

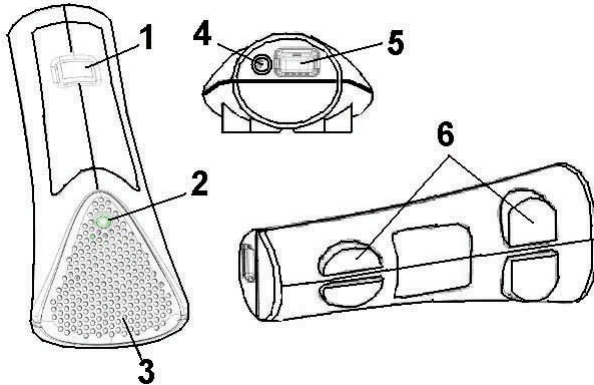

1. Mute button — press to mute, un-mute and pair microphone
2. LED display — visual status for mute, un-mute, and pairing
3. Integral grille — protects internal parts (non-removable)
4. Audio jack — accepts a 2.5mm plug
5. Charging port — docks to Charger Base
6. Rubber feet — non-slip, vibration absorbing pads

To use the Revolabs Solo™ Tabletop Microphone:

- Remove the microphone from the Charger Base to turn on and automatically mute the microphone (indicated by a flashing RED LED) during placement on the conference table.
- Tabletop microphones should be centered on the table with the integral grill pointed toward the users (uni-directional), or centrally located between users (Omni-directional), from 2 to 5 feet (.75 to 1.75m) away. It is always better to be as close to the person speaking as possible, but avoid placing the microphone where it might be blocked by equipment or meeting paperwork. Also do not place microphones too close to an audio or video conference speaker to avoid echoes.

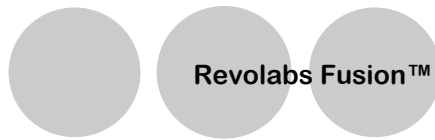

- With the microphone in position, un-mute the microphone by pressing and releasing the Mute button (confirm by viewing flashing GREEN LED).
- To turn microphone off, return the microphone unit to the Charger Base or press and hold the Mute button for ~10 seconds until the LED turns solid RED and release button.
- If the microphones are placed too far from the Base Station (~100 feet or 30 meters) the connection will be dropped (LED flashes all colors) and the microphone will mute. After 15 seconds the microphone will beep 5 times, and will continue beeping every 30 seconds to indicating it's out of range.
- Move the microphone closer to the Base Station and the connection will automatically be re-established to its original state, and the beeping will cease. If not, the microphone will continue beeping until it turns off in about 15 minutes.

Muting Microphones

In the default setting, each Solo microphone will mute only itself when its MUTE button on the microphone is pressed. To mute all of the microphones, press the red MUTE button on the Remote Control; all microphones will flash red and no individual microphone can be unmuted until the remote MUTE button is pressed again. All microphones will return to their prior state.

However, if the tabletop microphone master mute has been enabled (Refer to Set-Up Guide), the mute will work as follows: in addition to the Remote Control MUTE button muting all of the microphones, the Solo Tabletop microphone MUTE button will also act as a master mute and mute all active microphones. Pressing any Tabletop microphone MUTE button or the Remote Control MUTE button will unmute all tabletop microphones. All wearable and handheld adapter microphones in use will return to their prior state.

Using the Solo XLR Microphone Wireless Adapter

The Revolabs Solo™ Universal Wireless Adapter for Handheld Microphones, shown in the following figure, is connected to your existing handheld dynamic microphones for wireless freedom during open microphone meetings, Q&A sessions, classrooms, etc.

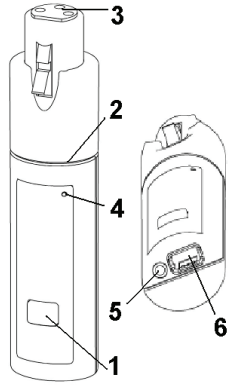

1. Mute button — press to mute, un-mute and pair microphone
2. Rubber collar — durable and impact/strain protection
3. XLR Female connector — balanced audio for dynamic microphones
4. LED display — visual status for mute, un-mute, and pairing
5. Audio Out port — accepts the 2.5mm plug for the earpiece
6. Power/Charging Port — docks to Charger Base

To use the Revolabs Solo™ Universal Wireless Adapter:

Remove the Microphone Adapter from the Charger Base.

The adapter turns on and mutes automatically when removed from Charger Base (flashing RED LED). The XLR Microphone Adapter is attached to a standard dynamic microphone to convert it from a wired microphone to a wireless microphone (see following figure).

The Adapter does not provide phantom power or bias current so it cannot be used with condenser or electret microphones.

With the microphone attached, un-mute the Adapter by pressing and releasing the Mute button (confirm by viewing flashing GREEN LED).

NOTE: If the microphone has an on-board mute switch, this switch must also be un-muted prior to use.

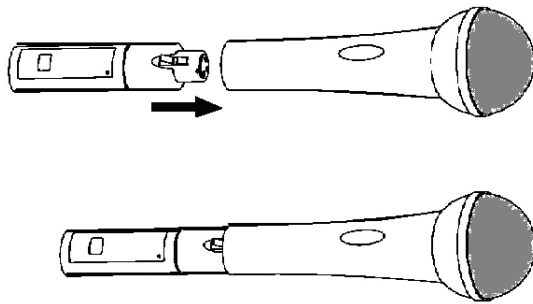

To turn the Adapter off, return the microphone unit to the Charger Base or press and hold the Mute button for ~10 seconds until the LED turns solid RED and release button.

Important: Always remove the microphone from the Adapter by pressing the latch switch and separating the parts before returning the Adapter to the Charger Base.

If the Adapter is moved too far from the Base Station (~100 feet or 30 meters) the connection will be dropped (LED flashes all colors) and the audio will mute.

After 15 seconds the microphone will beep 5 times, and will continue beeping every 30 seconds to indicate that it is out of range.

Move the XLR Adapter closer to the Base Station and the connection will automatically be re-established to its original state, and the beeping will cease. If not, the XLR Adapter will continue beeping until it turns off in about 15 minutes.

Muting Microphones

In the default setting, each Solo microphone will mute only itself when its MUTE button on the microphone is pressed. To mute all of the microphones, press the red MUTE button on the Remote Control; all microphones will flash red and no individual microphone can be unmuted until the remote MUTE button is pressed again. All microphones will return to their prior state.

However, if the tabletop microphone master mute has been enabled (Refer to Set-Up Guide), the mute will work as follows: in addition to the Remote Control MUTE button muting all of the microphones, the Solo Tabletop microphone MUTE button will also act as a master mute and mute all active microphones. Pressing any Tabletop microphone MUTE button or the Remote Control MUTE button will unmute all tabletop microphones. All wearable and handheld adapter microphones in use will return to their prior state.

Indicator Lights

Equipment Use	Microphone LED	Base Station LEDs	Meaning
Microphone in Charger Base	Solid RED	OFF	Charging in Progress
	Solid GREEN*	OFF	Charging Complete
Microphone not in Charger Base	OFF	OFF	Microphone powered OFF or battery discharged
	One RED flash every 1.5 seconds	RED Flashing	Microphone master muted by remote control or tabletop master mute
	Two RED flashes every 1.5 seconds	RED Flashing	Microphone paired and muted
	GREEN flash every 1.5 seconds	GREEN Flashing	Microphone paired and "live"
	Solid RED	Solid RED	Pairing mode or confirmation of powering-down.
	Alternating slow GREEN and RED	OFF or Alternating slow GREEN and RED	Microphone or channel not paired
	YELLOW flash alternating with GREEN	GREEN Flashing	Microphone low battery (mic live)
	YELLOW flash alternating with two RED flashes	RED Flashing	Microphone low battery (mic muted)
	Alternating RED, YELLOW, GREEN, YELLOW	OFF	Searching for a connection, or out of radio range. The Microphone will try to re-establish the link for about 15 minutes, and then turn off.
	Rapid RED flashes continuing for more than a few seconds	OFF	Radio congestion – it is not possible to make a radio connection because there are already too many nearby users, or there is heavy radio interference.
	Groups of five rapid RED flashes	OFF	Unit is faulty. Contact your AV service provider for advice.

Microphones must be fully charged and paired to the Fusion Base Station prior to first use.



© 2008 REVOLABS, INC. All rights reserved. No part of this document may be reproduced in any form or by any means without express written permission from Revolabs, Inc. Product specifications are subject to change without notice.