

Installation and Operation Guide

Revolabs xTag™ Wireless Microphone System Models 02-DSKSYS-D, 04-DSKSYSEU-D

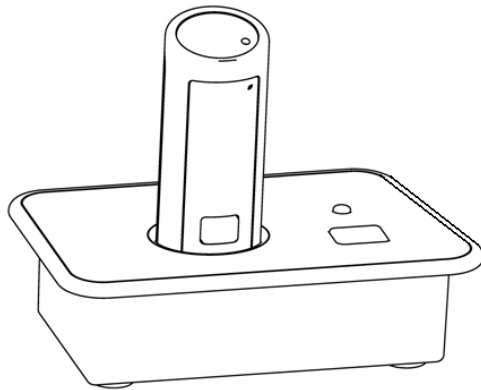

© 2007 REVOLABS, INC. All rights reserved. No part of this document may be reproduced in any form or by any means without express written permission from Revolabs, Inc. Product specifications are subject to change without notice.



Revolabs, Inc.

Revolabs xTag™ Manual
02-DSKMAN-DPP-11
December 2007 (Rev 1.5)

xTag

revolabs®

Table of Contents

Safety and General Information.....	1
Introduction	4
System Components	5
Revolabs xTag™ Charger Base	5
Mute Button	6
USB Connection.....	6
Installing the xTag USB System	6
Computer Software Set-up.....	6
Revolabs xTag™ Wireless Microphone	11
Using the xTag Microphone	11
Charging the Batteries.....	14
When to Charge	14
Setting the Broadcast Power Level	15
Pairing the Microphone to the Charger Base	16
Warranty	17
LED Status Indications	18
Revolabs xTag™ System Specifications	19

Safety and General Information

This section contains important information regarding safe and efficient operation, and declarations of required certification / regulation compliance. Please read this information prior to using your Revolabs xTag™ wireless microphone system.

FCC User Information

FCC Registration Number: 0014898290

FCC ID Number: T5V02DSKSYS Revolabs Charger

FCC ID Number: T5V01EXEMIC Revolabs Microphone

FCC Notice to Users

Users are not permitted to make changes or modify the equipment in any way. Changes or modifications not expressly approved by Revolabs, Inc. could void the user's authority to operate the equipment.

This device complies with Part 15 of the FCC Rules. Operation is subject to the following two conditions: (1) this device may not cause harmful interference, and (2) this device must accept any interference received, including interference that may cause undesired operation.

Federal Communications Commission (FCC) Radiation Exposure Statement

Important: This equipment complies with FCC radiation exposure limits set forth for an uncontrolled environment.

Industry Canada Notice to Users

Operation is subject to the following two conditions: (1) This device may not cause interference and (2) This device must accept any interference, including interference that may cause undesired operation of the device Ref IC: RSS 210 Sec. 5.11. The term "IC:" before the certification/registration number only signifies that registration was performed based on a Declaration of Conformity indicating that Industry Canada technical specifications were met. It does not imply that Industry Canada approved the equipment. See Ref IC Self-Marking 6(f) and RSP-100 Sec. 4.

IC ID Number: 6455A-02DSKSYS Revolabs Charger

IC ID Number: 6455A-01EXEMIC Revolabs Microphone

Restricted use with certain medical devices

Hearing Aids

Some devices may interfere with some hearing aids. In the event of such interference, you may want to consult with your hearing aid manufacturer to discuss alternatives.

Other Medical Devices

If you use any other personal medical device, consult the manufacturer of your device to determine if it is adequately shielded from RF energy. Your physician may be able to assist you in obtaining this information.

Export Law Assurances

This product is controlled under the export regulations of the United States of America and Canada. The Governments of the United States of America and Canada may restrict the exportation or re-exportation of this product to certain destinations.

For further information contact the U.S. Department of Commerce or the Canadian Department of Foreign Affairs and International Trade. The use of wireless devices and their accessories may be prohibited or restricted in certain areas. Always obey the laws and regulations on the use of these products.

02-DSKSYS North America UPCS Usage Restriction

Due to the UPCS frequencies used, this product is licensed for operation only in the United States of America and Canada.

04-DSKSYSEU European Union Usage Restriction

Due to the frequencies used, this product is licensed for operation only in the European Union countries.

European Compliance

This equipment has been approved in accordance with Council Directive 1999/5/EC "Radio Equipment and telecommunications Equipment."



Conformity of the Equipment with the guidelines below is attested by the CE mark.

Model Numbers:

04-DSKCHGEU-D Revolabs xTag™ Charger

04-DSKMIEU-D Revolabs xTag™ Microphone

Standards to which Conformity is declared:

RF ETSI EN 301 406 V 1.4.1 03/2001

EMC ETSI EN 301 489-6 v1.2.1 (2002-04)

WEEE Notification:

The Waste Electrical and Electronic Equipment (WEEE) directive (2002/96/EC) is intended to promote recycling of electrical and electronic equipment and their components at end of life.



2003/11/EC & 2002/95/EC "RoHS Compliance Directive":

The products referenced herein are in compliance with the EU directive 2003/11/EC and EU directive 2002/95/EC.

Introduction

Congratulations on the purchase of your Revolabs xTag™ USB wireless microphone system! This wireless system provides high band-width audio from a compact wireless microphone enabling reliable, secure, and untethered personal communication.

The xTag Wireless Microphone System is a unique marriage of innovative technology and ergonomic stylish design, featuring 1.9 GHz DECT technology. This product enhances audio communication in both personal and enterprise applications, using Multi-Carrier, Time Division Multiple Access and Time Division Duplex (MC/TDMA/TDD) radio transmissions both to and from the microphone.

This means that the system can co-exist with other wireless products such as wireless LANs (802.11 b&g) and cellular phones.

Note: *It is recommended that no more than 3 xTag Systems be used in the same room to avoid interference.*

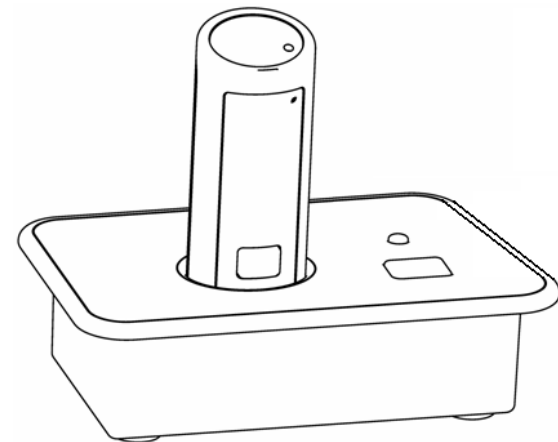

System Components

Your Revolabs xTag™ System package contains:

- Compact Charger Base
- Wearable xTag wireless microphone
- Earpiece with volume control
- Quick release lanyard
- USB cable
- Installation and Operation Guide
- xTag *Quick Start* Guide

Revolabs xTag™ Charger Base

Use the Charger Base to store and charge the Microphone when not in use. The Microphone must be properly inserted into the base and seated flush for charging to occur.

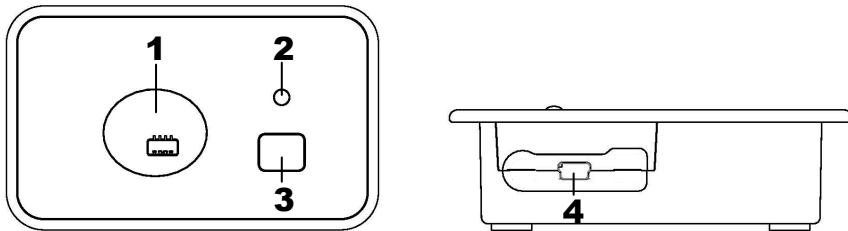

1. **Charger Bay** — charges Microphone
2. **LED indicator** — mute and pairing status indicator
3. **MUTE button** — duplicates the Microphone mute function
4. **Mini USB connector** — computer audio and power connection

Mute Button

Pressing the **MUTE** button toggles between muting (flashing RED LED status) and un-muting (flashing GREEN LED status) on the Wireless Microphone.

Note: Press the **MUTE** button on a Microphone will similarly toggle between mute and un-mute and display on both status LEDs.

USB Connection

Use the supplied cable to connect the mini USB connector to the Charger Base and the standard end to your computer USB port.

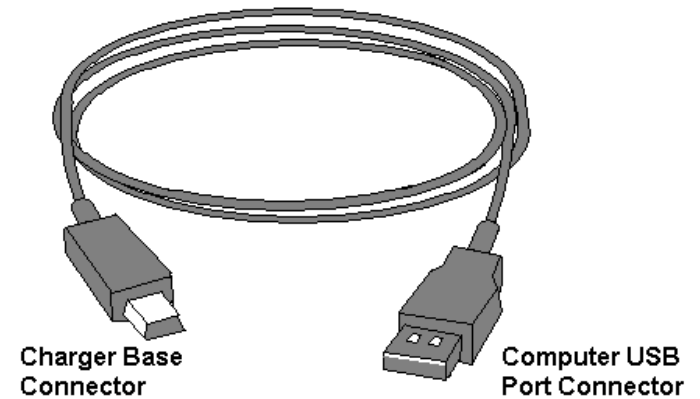

Installing the xTag USB System

The xTag USB system is easily installed in the home or office. Simply follow the instructions below to attach the unit to your equipment.

Computer Software Set-up

Use the supplied USB cable to connect the mini USB connector to the Charger Base and the standard end

to your computer USB port. Your computer will alert you that it has found a new USB device.

It is possible to configure your computer settings to playback audio through the earpiece attached to the Wearable microphone (default settings) or through the computer speakers (internal or desktop).

The following examples use the Microsoft Windows® XP Operating System Classic settings. You may notice slight differences in appearance when using other Windows operating systems.

To modify the default microphone earpiece audio output settings:

1. At the lower-right of your screen, click the Start button.



2. Select *Settings* and *Control Panel*.
3. Click the *Sounds and Audio Devices* icon.

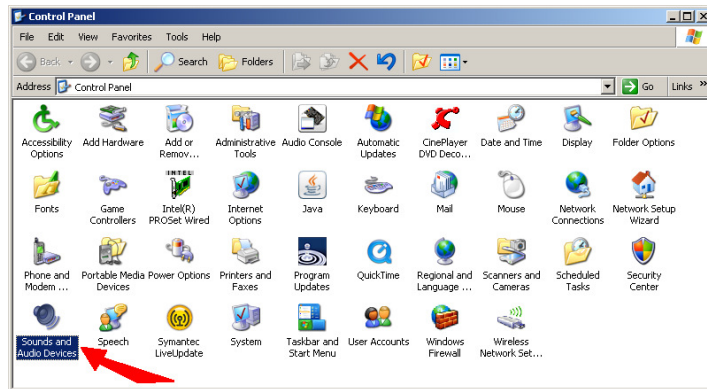

The Sounds and Audio Devices Properties dialog will display, as shown. The Revolabs xTag device will be selected.

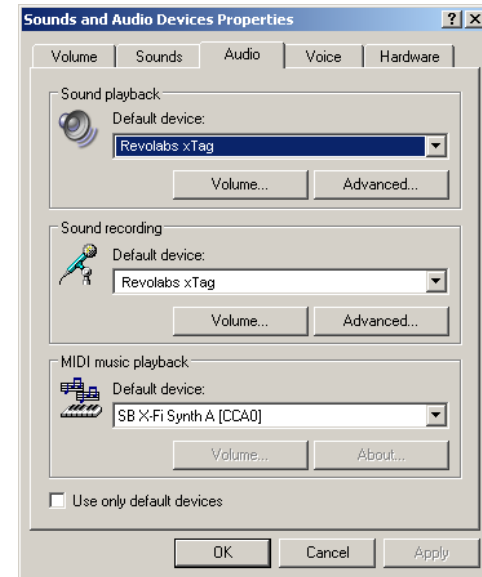

4. Open the *Volume* settings for *Sound recording* to view the volume levels selected for the microphone input (*Capture*) on the computer.

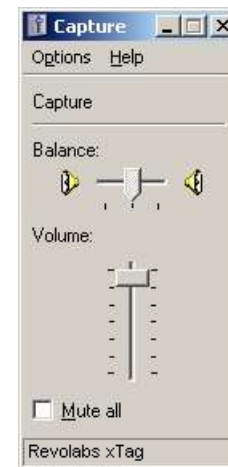

5. Make sure that the level for the Microphone is close to the top (maximum) and that the Mute box is not checked.
6. In the *Sound playback* section, open the Volume settings for to control the volume you hear in the Microphone's earpiece.

Adjust the *Speaker* level at the master Volume control if necessary.

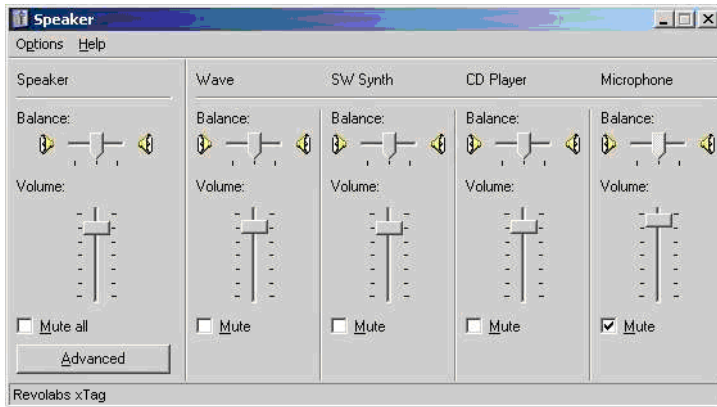

7. At the bottom of the Microphone section, click the *Mute* box in the *Microphone* section to prevent the Microphone directly feeding back its own audio to the earpiece (i.e. “sidetone”).

It may be necessary to use the Options-Properties menu to display the *Microphone* volume control.

IP telephony and computer telephony applications (e.g., Skype) may also offer options for controlling the audio levels and playback capabilities. Please consult the application guide for the software package for additional instructions.

8. Change the Sound playback Default device to your regular audio codec (SigmaTelAudio in this

example) to playback audio through the internal or external speakers of the computer instead of the earpiece.

9. At the bottom of the dialog, click *Apply*, and then click *OK*.

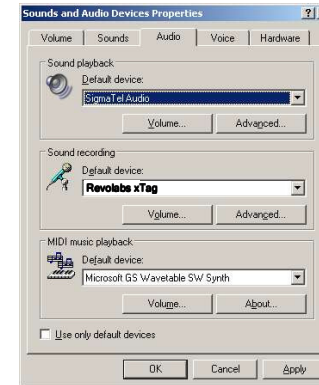

Note: Laptop computers with built-in microphones may continue to operate even when the xTag software is running. To prevent the built-in microphone audio feeding through to the speakers, check the Mute box on the laptop audio program Input Monitor, as follows.

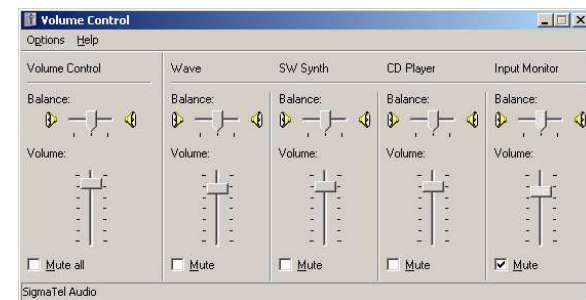

Revolabs xTag™ Wireless Microphone

The xTag wireless microphone uses encrypted communication to synchronize with the Charger Base. The xTag Microphone provides high quality full duplex audio between the user and the computer.

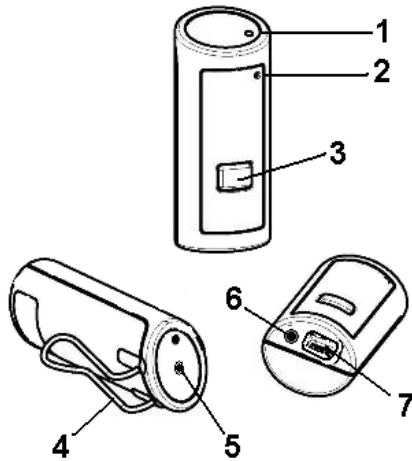

1. Microphone Port – Receives audio
2. Noise Cancellation Port
3. Mute Button — press to mute, un-mute and pair microphone.
4. Pocket clip — attaches microphone to user or Lanyard.
5. LED display — visual status for mute, un-mute, and pairing.
6. Earpiece jack — accepts the 2.5mm plug for the earpiece.
7. Charging port — charges in xTag charger base.

Using the xTag Microphone

1. Remove the Microphone from the Charger Base. The double-flashing RED LED on the Microphone and Charger Base confirm that the mic is paired and muted.

The Wireless Microphone has a clip on the back which allows the Microphone to be easily attached onto a shirt pocket, blouse, lapel or lanyard.

2. Attach the Microphone to clothing or to a lanyard close to the mouth, within 6-12 inches (15–30cm) is recommended. Make sure microphone is attached securely with the microphone port pointed up toward mouth.
3. With the microphone in the wearing position, un-mute the microphone by pressing and releasing the Mute button (confirm by viewing flashing GREEN LED). If the volume is too low, move the microphone closer to the mouth.
4. To turn the microphone off, return the Microphone to the Charger Base. The Microphone LED will show a 5 second self-test pattern and begins charging (solid RED or GREEN LED). Alternately, turn off the Microphone manually by pressing and holding the Mute button for 10 seconds, until the LED turns solid RED, then release the mute button and the LED will turn OFF.

If the microphone is moved out of range of the Base Station (~65 feet or 20m) the connection will be dropped (LED flashes all colors) and the microphone will mute.

After 15 seconds the microphone will beep 5 times, and will continue beeping every 30 seconds to remind the user to return the microphone to the room. If the microphone is moved back into range within 15 minutes the connection will automatically be re-established to its original state, and the beeping will cease. If not, the microphone will turn off.

Note: The xTag microphone is designed to be used with the xTag system only. This microphone is not compatible with other Revolabs Solo™ Executive systems, nor are Solo microphones compatible with the xTag Charger Base.

Adjusting the Volume on the xTag Microphone Earpiece

To change the volume on the Wearable microphone earpiece, use the dial on the earpiece wire.

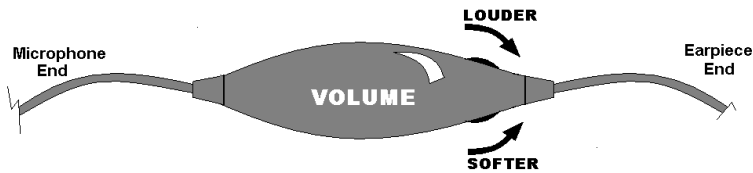

Turning the dial towards the earpiece, as shown in the figure, will increase the volume, and turning the dial towards the microphone will decrease the volume. Use the attached clothing clip to secure the earpiece wire.

Charging the Batteries

To charge the batteries place the Microphone into the xTag Charger Base.

Note: *The unit will only work on a powered USB port that can supply 500mA (found on most computers and laptops). It will not work with un-powered hubs (no AC adapter to power the hub).*

During charging, the Microphone status LED indicator changes from solid RED to solid GREEN as charging completes. The Charger Base status indicator remains off during charging. The Microphone is always muted while in the Charger Base. The battery charges from fully depleted to fully charged in approximately two hours, however, it is “quick-charged” to 80% capacity in 45 minutes.

Note: *A fully charged battery provides approximately 8 hours of talk time.*

When to Charge

Before using the Microphone for the first time, charge for 8 hours or overnight in the Charger Base (until microphone LED turns solid GREEN).

When the Microphone LED begins flashing alternating YELLOW and RED or YELLOW and GREEN, the battery needs recharging. Over time (years), batteries gradually wear down and require charging after a shorter period of use. This is normal.

Important: The Lithium Polymer rechargeable battery that powers the xTag Microphone is not user serviceable. Please see the Revolabs website (www.revolabs.com) for information regarding battery replacement and proper disposal procedures.

Warning: Exposing the batteries to fire may result in an explosion.

Setting the Broadcast Power Level

In confined settings where multiple xTag systems are used, or where audio interference is likely, it may be necessary to reduce the broadcast power levels.

The broadcast power level between the xTag Microphone and Charger Base can be set to the following three levels.

- Highest power level – 60 feet (25M) maximum operating distance between Microphone and Charger Base (default setting).
- Medium power level – 20 feet (7M) maximum operating distance between Microphone and Charger Base.
- Lowest power level – 6 feet (2M) maximum operating distance between Microphone and Charger Base.

To set the broadcast power level:

Press and hold the Mute button on the Charger Base while plugging the USB cable into the Charger Base.

The status LED on the Charger Base will display a sequence of flashes, during which it will flash once, then twice, then three times, where:

- 1 GREEN flash = full power
- 2 GREEN flashes = medium power
- 3 GREEN flashes = low power.

This cycle will repeat 10 times. During any of the cycles, simply release the Mute button immediately after the desired power indication, to set the xTag broadcast/receive power.

Pairing the Microphone to the Charger Base

“Pairing” creates an encrypted association between the Wireless Microphone and the Charger Base with a unique electronic serial number. Once the Microphone and Charger Base have been paired, the Microphone will automatically try to connect to the Charger Base whenever it is lifted from the Charger Base.

Remember, the Microphone is always muted (flashing RED LED) when it is first removed from the Charger Base and the MUTE button needs to be pressed to activate the Microphone, as indicated by a flashing GREEN LED.

The Microphone in new systems come paired to the Charger Base. However, if a replacement Microphone is ever required, it will need to be manually “paired.”

If a Microphone is lifted from the Charger Base and the Microphone LED slowly flashes alternating RED and GREEN for 10 seconds, it means that the Microphone needs to be paired to the system.

To pair the Microphone to the Charger Base:

1. Make sure the Microphone is turned OFF (no LED activity). If the unit is ON, press and hold the MUTE button for 10 seconds until the LED turns solid RED then release. Alternately, place the Microphone in the Charger Base for less than 2 seconds.
2. Enable the pairing mode by holding the Microphone’s Mute button down for eight seconds.

The LED will turn solid GREEN and then solid RED. Release the Mute button. The Microphone unit is now in *pairing* mode.

3. Push and hold the Charger Base's Mute button for eight seconds to enter into pairing mode then release.

The LED will be solid RED until pairing is complete, as indicated by double flashing RED on both the Microphone and the Charger Base (paired and muted audio). If pairing fails at the end of one minute on either unit, the LED will flash alternately GREEN and RED for a few seconds and turn OFF. If this happens, repeat these steps.

Warranty

Revolabs, Inc. warrants this product to be free of manufacturing defects. Repair or replacement of any defective part or unit (at the discretion of the Seller) will be free of charge for the period of 90 days.

Any attempt by the user to alter the equipment, or equipment damaged by negligence, accident, or Acts of God voids this warranty.

The Seller shall not be liable for any consequential damage resulting from the malfunction of this product. Should the user experience unsatisfactory performance from this equipment, contact the Seller to obtain instructions for return, or replacement, as deemed necessary.

This warranty is not transferable by the original end user.

Revolabs, Inc.
63 Great Road
Maynard, MA 01754
www.revolabs.com
1-800-326-1088

LED Status Indications

The following LED patterns are shown on either the Microphone or the Charger Base.

LED pattern	Meaning
Solid GREEN (Microphone only*)	Confirmation of power-up or battery reaching full charge. * In earlier versions LED will turn OFF when fully charged.
Solid RED	Pairing mode, or confirmation of powering-down, or battery charging.
GREEN flash every 1.5 seconds	Microphone paired, connected and un-muted.
Two RED flashes every 1.5 seconds	Microphone paired, connected and muted.
YELLOW flash alternating with GREEN flash	Microphone paired, connected, un-muted and battery low.
YELLOW flash alternating with two RED flashes	Microphone paired, connected, muted and battery low.
Alternating RED, YELLOW, GREEN, YELLOW (Microphone only)	Searching for a connection, or out of radio range. The Microphone will try to re-establish the link for about 15 minutes, and then turn off automatically. The Microphone will beep five times every 30 seconds.
Alternating RED, GREEN	Microphone is not paired to this Base Station.
Rapid RED flashes continuing for more than a few seconds	Radio congestion – it is not possible to make a radio connection because there are already too many nearby users of the RF band, or there is heavy radio interference.
Groups of five rapid RED flashes	Unit is faulty. Please contact your place of purchase for advice on return.

Revolabs xTag™ System Specifications

Dimensions, (L, W, H) and Weight

XTag Charger Base

3.9" (10 cm) x 2.4" (6 cm) x 1.0" (2.56 cm), 0.5 lb (0.23 kg)

Wireless Microphone

0.9" (2.4 cm) x 0.8" (1.95 cm) x 2.6" (6.68 cm), 0.05 lb (0.02 kg)

Shipping Weight 1.5 lbs (0.68 kg)

Radio Frequency

02-DSKSYS-D 1.92 to 1.93 GHz (UPCS North America)

04-DSKSYSEU-D 1.88 to 1.90 GHz (DECT EU)

Connectors

XTag Charger Base

Mini USB – 5 pin connector, USB 2.0

Wireless Microphone

Power – proprietary 4 pin connector

Audio – 2.5mm mono audio

Microphone pattern Unidirectional – cardioid.

Battery Lithium Polymer, up to 8 hours talk time

Charge Time 2.0 hours approx.

Range 65' (20 meters) approx. (no obstructions)

Audio Bandwidth 100-7000 Hz

Security 128-bit DSAA (DECT Standard Authentication Algorithm) authentication, 64 bit DECT Standard Cipher

Environmental Requirements

Temperature 40° to 105° F (5° to 40° C) operating

Humidity 20% to 85%

Note: *Microphones must be fully charged and paired to the Charger Base prior to first use.*

